

1. Introduction

Model HS-002 is a compact high performance fan/heatsink combo designed for general cooling of high heat flux devices. The heatsinks are nickel plated with integrated heatpipes that are soldered in place to maximize heat transfer;. Heatpipes are known to have extremely high thermal conductivity; six heatpipes make sure any concentrated heat source on any where of the heatsink base is spread over the entire base; this minimizes the spreading resistance and maximize the effectiveness of the heatsink fins.

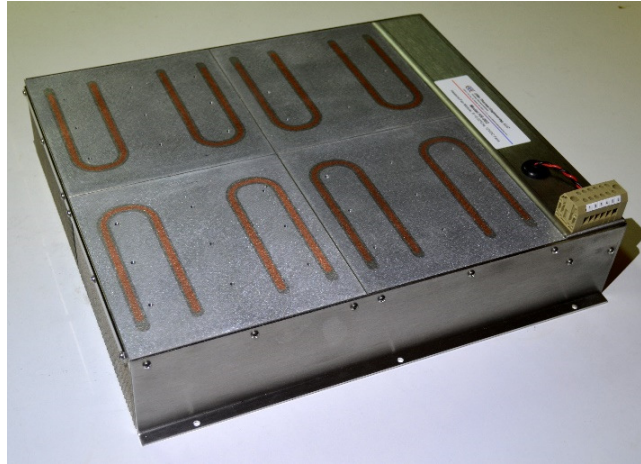

The fins are forged in place; forged fins are much more superior than bonded fins because there are no low conductivity epoxies at the joint between the fins and heat sink's base. The fins are also periodically segmented to break down the laminar layer of the airflow. Breaking down the laminar air flow increases turbulence and improve cooling effectiveness.

HS-002 comes with a high quality terminal block with 20A rating per contact for fan wiring and high power laser wiring. The five high power fans are hidden inside of the air duct, reducing the noise significantly.

Custom mounting holes patterns is available upon request or users can add their own mounting holes as they wish.

2. Performance

The thermal resistance of model HS-002 is 0.02°C/w from heatsink to ambient

3. Cooling Fan Specifications

There are 5 cooling fans wired in parallel. Each fan is specified as below.

Parameters	Standard
Rated voltage	12VDC
Operating voltage range	4.5 – 13.8 VDC
Input power	4.08w
Rated current	.34A
Noise	46.5dBA

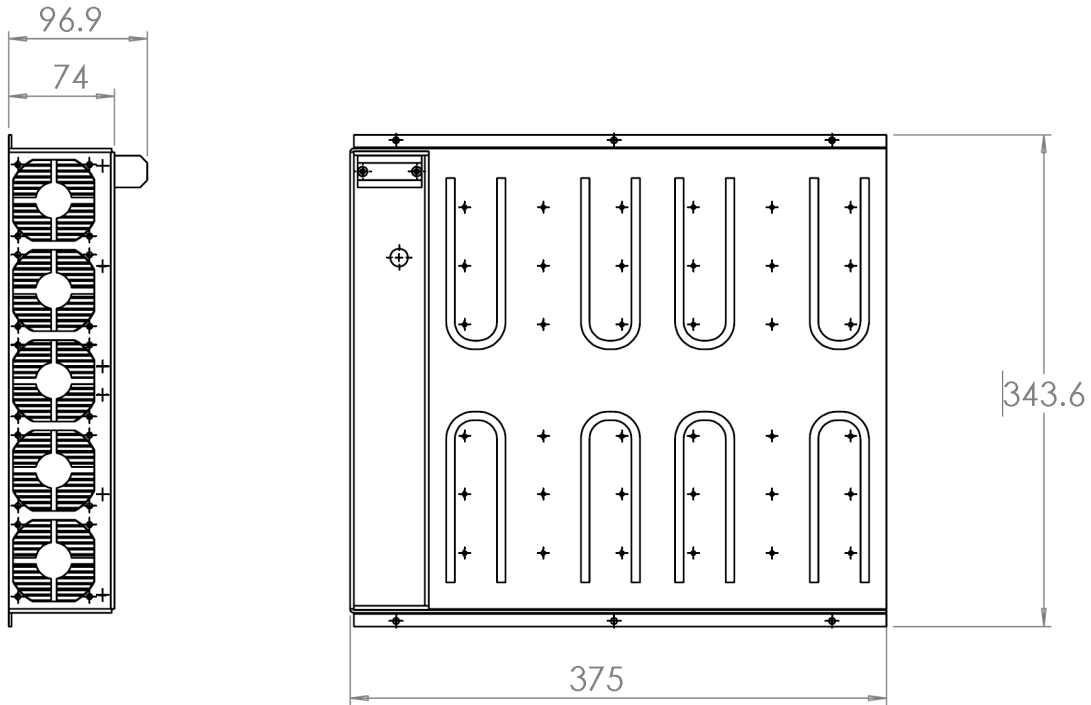

4. Pricing and Contacts

For pricing and availability, please contact ETE:

Elite Thermal Engineering

22914 11th Ave, W, Bothell, WA 98021

Phone: 425-770-8147

Fax: 425-953-1333

Email: contact@elitethermalengineering.com