

1. Introduction

OCP-055 is a high performance cooling module designed for OEM applications for laser products, medical equipments and semiconductor processing. It is also designed for general cooling of standard CS mount laser diode bars in laboratory environment. It also provides mounting holes for standard 25w class QPC lasers.



Figure 1 below outlines the functional hole patterns. It has two locations for CS mounts ---- the one in the front is for easily using it for free-space laser systems, and the middle one is for fiber coupled packaged CS diode bars or multiple lower power diodes. The 4 flanges on top of heatsink are designed for mounting to optical table with 1/2" posts. Custom mounting holes patterns is available upon request.

The cold plate is electrically isolated from the heatsink and the fan duct. So it is safe to mount the CS diode directly on the cold plate using indium foil.

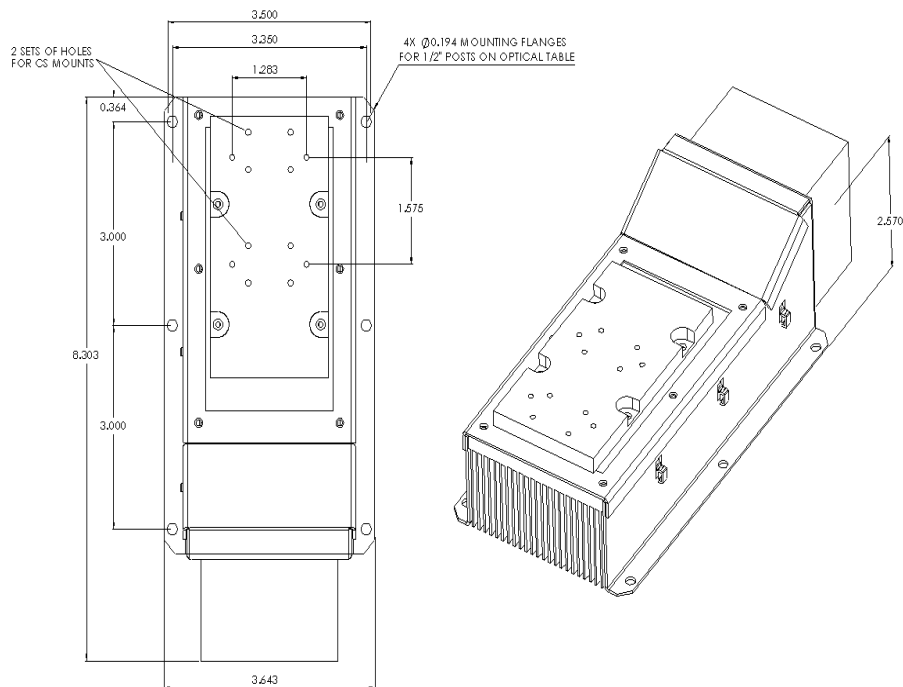
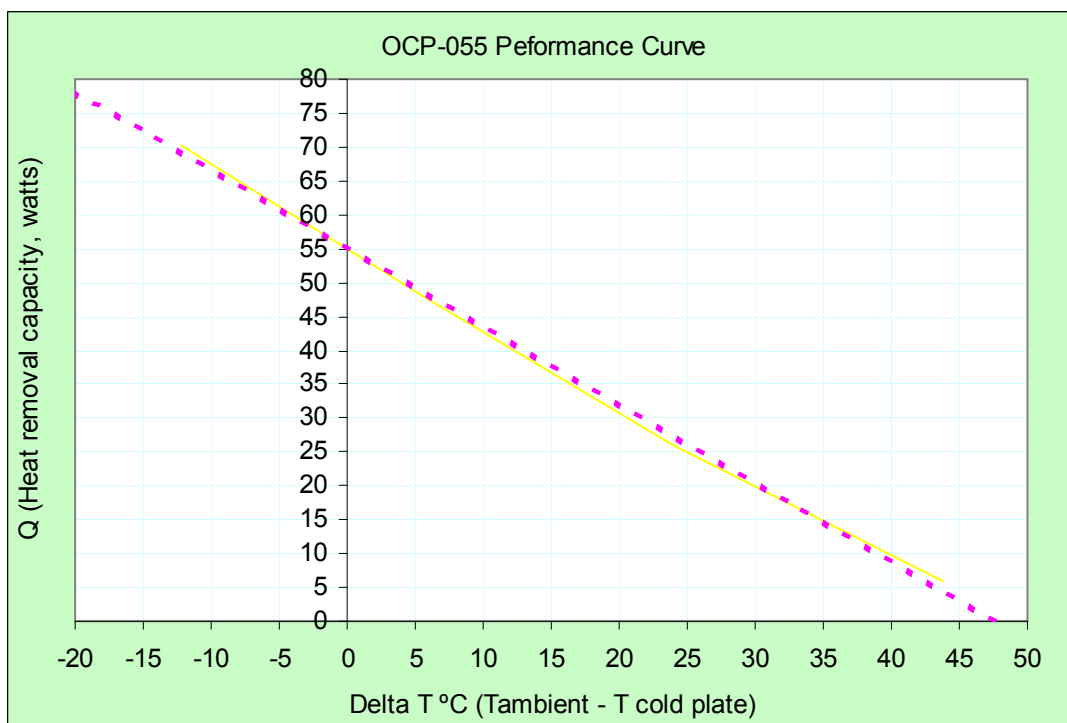

Figure 1 Functioning Hole Patterns of the ColdPlate

2. Performance curve

The following curve illustrates the performance of OCP-055. The Y-axis is the heat load to the cold plate, the X-axis is the delta between the lowest temperature on cold plate and ambient at the given heat load. Please notice that the cold plate temperature is an average figure, the temperature directly underneath the diode source will be higher and the edge of the cold plate will be lower. This curve is obtained with 3.6Amps current to each TEC with the cold side set at 25°C. The performance will improve in hotter set points and decrease if the set point is lower.



3. Cooling Approach

The fan pulls air away from front of heatsink in our standard configuration of the cooling module. It makes it easy to use on optical table with CS diode mounted on it since the air is pulling away from the optics. For applications where pushing air out from the front is not a concern, users can easily take the fan off and change the direction of the airflow; and the performance will be slight better.

4. Cooling Fan Specifications

Parameters	Standard
------------	----------

Rated voltage	12VDC
Operating voltage range	5.5~13.8 VDC
Input power	9.9w
Rated current	.83A
Noise	47dBA

5. TEC specifications

The maximum operating current for each TEC is 4.2 A, and maximum voltage is 14VDC at room temperature. Maximum operating current and voltage increases with ambient. Exceeding the specified maximum current will reduce the performance and degrade the reliability of TECs.

The typical optimum current for each TEC is about 3~4 Amps depends on the set temperature, heat load, interface quality between the diode and cold plate, and ambient temperature.

We highly recommend driving the 2 TECs in series to ensure optimum performance. The TECs shall run from constant current source.

Users are advised to manually ramp the TEC driving current after assembling the diode on the cold plate to identify the optimum current and set current limit accordingly so that the TEC will not runaway.

All TECs are environmentally sealed for operating below dew points.

6. Diode Cooling Interface Guidelines

The actual performance of the cooling module is extremely sensitive to the quality of the thermal interface between the cold plate and the diode. For high power laser modules with large footprints, it is very difficult to maintain uniform high quality interface. Our cold plate is made of copper with very low spreading resistance so that the user can focus the attention primarily to the area directly underneath the laser diodes.

If diode set temperature is significantly below ambient, we highly recommend using thermal insulation materials such as silicone foam or ceramic-based insulation to insulate laser from ambient.

7. Pricing and Contacts

The price for OCP-055 is \$428.56 for low quantities. For volume discount or if you need further information or clarification, please contact ETE in any of the following options:

Elite Thermal Engineering

22914 11th Ave, W, Bothell, WA 98021

Phone: 425-770-8147

Fax: 425-485-0486

Email: contact@elitethermalengineering.com
www.elitethermalengineering.com