

1. Introduction

OCP-150 is a high performance thermoelectric cooling module designed for OEM applications for high power laser products, medical equipments and semiconductor processing. It is also a convenient solution for general cooling of common fiber coupled lasers in laboratory environment.

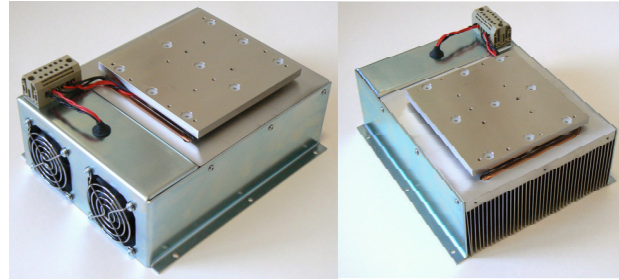

The outline provides the functional mounting hole patterns for the most popular fiber coupled laser diodes from QPC (Brightlase Ultra), nLight (Pearl) and LIMO, Jenoptik (JOLD-30), and Coherent. Custom mounting hole pattern is available upon request. We also accept customer provided cold plates and install it in place of our standard cold plate.

The heatsink we use for OCP-150 is our model HS-008. HS-008 has three heat pipes embedded in the base of the heatsink to minimize heat spreading resistance; both heat pipes and heatsink are nickel plated and soldered together. HS-008 is available for sale as a standalone unit. It is a great solution for high power lasers, electronics, IGBTs, etc.

All electrical connections are provided through the terminal block. The table above lists the pin out designations.

ETE also offers OCP-150 in 48V versions. Please contact ETE for more information.

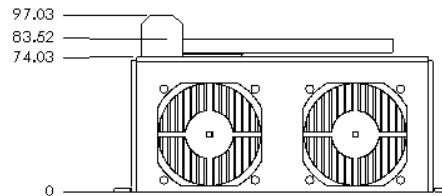
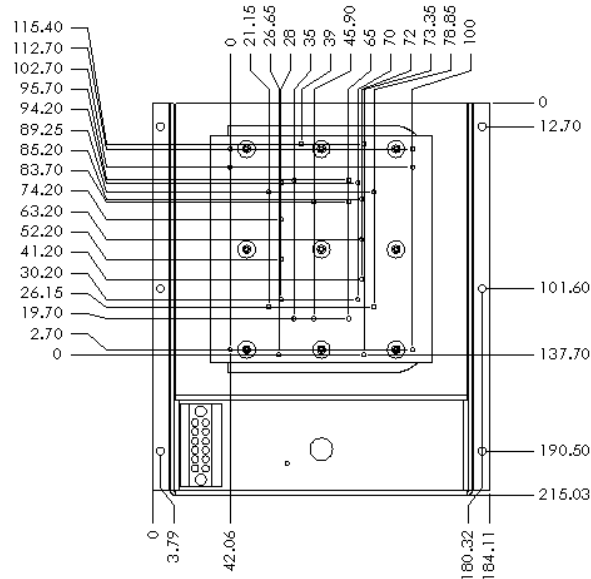

2. Performance curve

The curve on the right illustrates the performance of OCP-150 at various current in room ambient temperature. The X-axis is the heat load to the cold plate, the Y-axis is the cold plate temperature at the heat load. Please notice that the cold plate temperature is an average figure, the temperature of the cold plate is very uniform ($<0.5^{\circ}\text{C}$) with evenly distributed heat load; when used to cool high power laser diode, the temperature directly underneath the diode source will be slightly higher than the edge of the cold plate. The following curve indicates the optimum current to individual TEC is 3-3.6A depends on the operating point. The performance, optimum current, maximum rating all changes depends on the heat load, cold side set temperature and ambient temperature.

3. TEC and fan specifications

There are two sets of TECs in OCP-150 that are pre-wired and routed to the terminal block. The maximum operating current for each TEC set is 4.2 A, and maximum voltage is 36VDC at room temperature. Maximum operating current and voltage increases if ambient is higher. Exceeding the specified maximum current may reduce the performance and degrade the reliability of TECs. We highly recommend driving the 2 TEC sets in series to ensure optimum performance. The

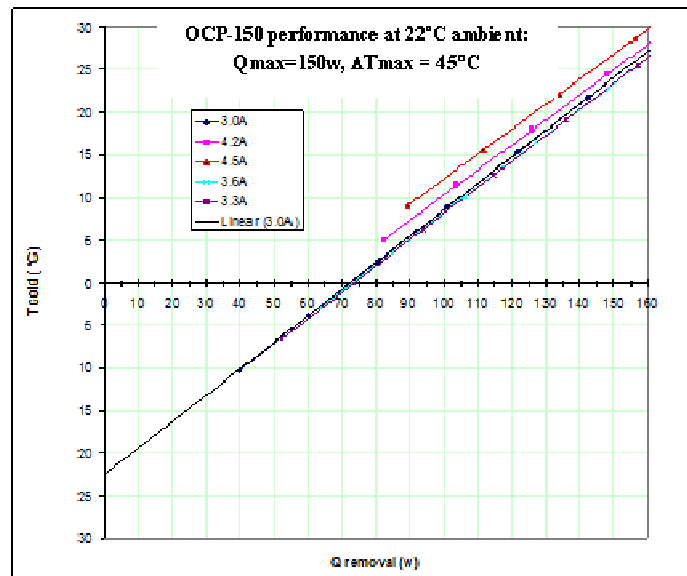

TECs shall run from constant current source.

Users are advised to manually ramp the TEC driving current after assembling the diode or other heat load on the cold plate to identify the optimum current and set current limit accordingly so that the TEC will not runaway.

All TECs are environmentally sealed for operating below dew points. The maximum rated operating temperature for TECs is 150°C. The thermal resistance from TEC to ambient of OCP-150 heatsink is 0.08°C.

4. Diode Cooling Interface Guidelines

The actual performance of the cooling module is extremely sensitive to the quality of the thermal interface between the cold plate and the diode. For high power laser modules with large footprints, it is very difficult to maintain uniform high quality interface. Our cold plate is made of copper with very low spreading resistance so that the user can focus the attention primarily to the area directly underneath the laser diodes.

If diode set temperature is significantly below ambient, we highly recommend using thermal insulation materials such as silicone foam or ceramic-based insulation to insulate laser from ambient.

5. Pricing and Contacts

For pricing and availability, please contact ETE in any of the following options:

Elite Thermal Engineering

22914 11th Ave, W, Bothell, WA 98021

Phone: 425-770-8147

Fax: 425-953-1333

Email: contact@elitethermalengineering.com

Pin # marked on terminal block	Designation	Maximum rating
1	TEC set 1 +	4.2A x 36V
2	TEC set 1 -	
3	TEC set 2 +	4.2A x 36V
4	TEC set 2 -	
5	Fan +	1.1A x 12V
6	Fan -	

Fan parameters	Standard
Rated voltage	12VDC
Operating voltage range	5.5-13.8 VDC
Input power	9.9w
Rated current	1.66A
Noise	47dBA